

DATA CENTERS



CRITICAL
INFRASTRUCTURE



GOVERNMENT/
JUDICIAL



MILITARY/DEFENSE
FACILITIES



EMBASSIES/
DIPLOMATIC
COMPOUNDS

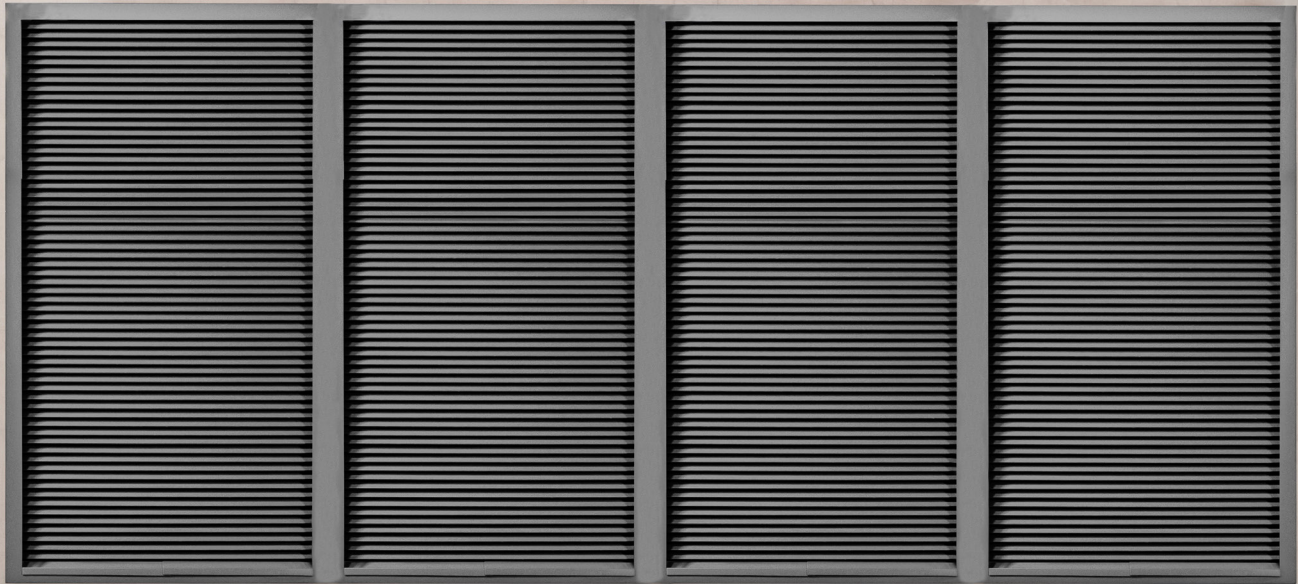

DESIGNING AGAINST BALLISTIC THREATS



WHY HIGH-SECURITY LOUVERS ARE ESSENTIAL TO A
HARDENED BUILDING ENVELOPE



EXECUTIVE SUMMARY

Ballistic threats represent one of the most severe and immediate risks to high-security facilities. While walls, doors, and glazing systems are routinely specified to withstand ballistic threats, louvers are often overlooked, creating a critical vulnerability in an otherwise hardened building envelope.

Louvers are essential for airflow to data centers, generators, mechanical rooms, and HVAC systems. However, when not specifically engineered for ballistic resistance, they can allow projectiles to penetrate into protected spaces, endangering occupants, critical infrastructure, and disrupting operations.

For instance, many data centers rely on exterior generators or gensets to provide backup power. Unlike the main structure, these units may not be protected by reinforced walls, doors, or ballistic glazing. At the same time, generators require substantial airflow for operation and heat dissipation. Without a ballistic-rated louver system, a bad actor could potentially fire through a perimeter fence and compromise the generator, disrupting backup power and threatening the resilience of the entire facility.

This white paper examines:

- The ballistic risks associated with conventional louvers
- Relevant ballistic testing standards (UL 752, DOS SD-STD-01.01 Rev G Amended)
- Guidance for specifying louvers capable of resisting ballistic threats without compromising ventilation or architectural intent

THE BALLISTIC THREAT LANDSCAPE

Ballistic attacks are a risk factor for many high-security facilities, including data centers, critical infrastructure sites, government buildings, military installations, and embassies. Unlike forced-entry attacks, ballistic assaults can be carried out rapidly, from a distance, and without physical contact with the building envelope.

Because louvers are inherently open systems designed for airflow, they are often perceived as a vulnerability rather than protective barriers. However, in a ballistic attack, an inadequately designed louver can become a direct line of sight into secure spaces.

To achieve true ballistic continuity across a building envelope, louvers must be specified and designed as protective assemblies, on par with threat resistant doors and exterior glazing, rather than treated solely as mechanical components.

Where Ballistic-Resistant Louvers Are Critical

Ballistic attacks differ qualitatively from forced entry: they can be rapid and at a distance. Facilities at heightened risk include:

- **Data centers and secure IT environments** that are high-value targets for continuity disruption, where louvers ventilate generator rooms, uninterrupted power supply (UPS) rooms, battery storage areas, and cooling systems
- **Critical infrastructure facilities** such as power plants, water treatment facilities, and telecom hubs, where damage can cascade; louvers protect essential mechanical and electrical equipment
- **Government and judicial buildings** with adjacent public access and symbolic prominence, where mechanical rooms and backup power systems often rely on exterior ventilation
- **Military and defense facilities** supporting mission-critical operations, where hardened envelopes must extend to all airflow openings
- **Embassies and diplomatic compounds** with high public visibility and elevated geopolitical risk, where exposed mechanical systems and generator yards require both airflow and ballistic protection

In these applications, louvers must resist penetration while continuing to support airflow essential to facility operation.

Ballistic Resistance: The Primary Performance Requirement

Standard commercial louvers prioritize airflow, weather resistance, and aesthetics. Their typical thin aluminum blades and lightweight frames are not designed to resist bullets or fragments. In safety and security scenarios involving gunfire, conventional louvers typically perform as follows:

- **Penetration:** Projectiles traverse open paths or through light-gauge materials into occupied/sensitive spaces.
- **Fragmentation:** Bullet and blade breakup increase injury and equipment damage.
- **System compromise:** Downstream filters, coils, servers, and switchgear are impacted.



























Result: A single ballistic event can cause life safety risks, system outages, and mission failure.

STANDARDS AND CERTIFICATIONS FOR BALLISTIC RESISTANCE

Note: Always confirm the latest edition and test protocols with the issuing body during specification.

UL 752 (11th Edition): Ballistic Resistance of Materials

UL 752 is a widely recognized standard that evaluates a product’s ability to resist specified ammunition. Levels commonly referenced in building applications include:

UL 752 11TH EDITION STANDARD FOR BULLET-RESISTANT MATERIALS TESTING						
LEVEL	WEAPON	AMMUNITION	WEIGHT	VELOCITY	SHOTS	APPLICABLE INDUSTRIES
1	 9MM PISTOL	9MM FULL METAL COPPER JACKET WITH LEAD CORE	124 GRAIN 8 GRAMS	1175 FPS TO 1293 FPS		SCHOOLS RETAIL GAS STATIONS
2	 .357 MAGNUM REVOLVER	.357 MAGNUM JACKETED LEAD CORE SOFT POINT	158 GRAIN 10.2 GRAMS	1250 FPS TO 1375 FPS		SCHOOLS RETAIL GAS STATIONS
3	 .44 MAGNUM REVOLVER	.44 MAGNUM LEAD SEMI-WADCUTTER GAS CHECKED	240 GRAIN 15.6 GRAMS	1350 FPS TO 1485 FPS		SCHOOLS RETAIL GAS STATIONS
4	 .30 CALIBER RIFLE	.30 CALIBER RIFLE LEAD CORE SOFT POINT	180 GRAIN 11.7 GRAMS	2540 FPS TO 2794 FPS		MUNICIPAL BUILDINGS BANKS PHARMACEUTICALS
5	 M14 RIFLE	7.62MM RIFLE LEAD CORE FULL METAL COPPER JACKET MILITARY BALL (M80)	150 GRAIN 9.7 GRAMS	2750 FPS TO 3025 FPS		DATA CENTERS SAFE HAVENS COURTHOUSES
6	 9MM SUBMACHINE GUN	9MM FULL METAL COPPER JACKET WITH LEAD CORE	124 GRAIN 8 GRAMS	1400 FPS TO 1540 FPS		DATA CENTERS SAFE HAVENS FEDERAL GOVERNMENT BUILDINGS
7	 AR-15	5.56MM RIFLE FULL METAL COPPER JACKET WITH LEAD CORE (M193)	55 GRAIN 3.56 GRAMS	3080 FPS TO 3388 FPS		SCHOOLS EMBASSIES CRITICAL INFRASTRUCTURE
8	 M14 RIFLE	7.62MM RIFLE LEAD CORE FULL METAL COPPER JACKET MILITARY BALL (M80)	150 GRAIN 9.7 GRAMS	2750 FPS TO 3025 FPS		FINANCIAL INSTITUTIONS MILITARY FACILITIES CRITICAL INFRASTRUCTURE
9	 .30-06 RIFLE	ARMOR PIERCING .30 CALIBER RIFLE STEEL CORE LEAD POINT FILLER FULL METAL JACKET	166 GRAIN 10.8 GRAMS	2715 FPS TO 2987 FPS		MILITARY FACILITIES HARDENED WALLS ARMOURED VEHICLES
10	 .50 CALIBER RIFLE	.50 CALIBER RIFLE LEAD CORE FULL METAL COPPER JACKET, MILITARY BALL (M2)	709.5 GRAIN 45.9 GRAMS	2810 FPS TO 3091 FPS		MILITARY FACILITIES HARDENED WALLS ARMOURED VEHICLES
SHOTGUN I	 12 GAUGE	12-GAUGE RIFLED LEAD SLUG	437 GRAIN 28.3 GRAMS	1585 FPS TO 1744 FPS		SCHOOLS CONVENIENCE STORES BANKS
SHOTGUN II	 12 GAUGE	12-GAUGE 00 BUCKSHOT (12 PELLETS)	650 GRAIN 42 GRAMS	1200 FPS TO 1320 FPS		SCHOOLS CONVENIENCE STORES BANKS

Advanced Ballistic Threat Protection

For facilities facing elevated threat profiles, handgun resistance alone may be insufficient. Maximum-security louvers can be engineered to resist rifle fire, including multiple impacts in close proximity. These systems incorporate:

- Reinforced blade geometry
- Internal ballistic baffles
- Heavy-gauge materials designed to defeat or capture projectiles

U.S. Department of State SD-STD-01.01 Rev G (Amended) (FEBR)

The DOS SD-STD-01.01 Rev G (Amended) standard, often associated with Department of State (DOS) Overseas Buildings Operations (OBO), is among the most rigorous protocols, combining ballistic and forced-entry testing. Forced Entry/Ballistic Resistant (FEBR) assemblies undergo:

- Multiple rifle shots with three ammunition types
- Targeted impact locations to probe weak points
- Sequential testing to assess cumulative damage
- Unstructured mob-style attacks with hand tools to determine resistance to forced entry

Implication for Louvers: A louver passing DOS Rev. G FEBR testing has attained one of the highest commercially available protection levels and is suitable for maximum-security applications.

AIRFLOW REQUIREMENTS AND CONSIDERATIONS

Louvers play a critical role in providing adequate airflow to ensure that equipment and systems operate efficiently. Without sufficient airflow, components may experience reduced performance, overheating, or premature failure. Airflow capacity and pressure drop must be carefully evaluated during the design and selection process using data gathered from testing to AMCA 500 protocols, which are standardized laboratory testing methods for airflow, pressure drop, and water penetration performance. AMCA 500-L and AMCA 550 evaluate louver performance to verify airflow characteristics and resistance to wind-driven rain.

In high security applications, louvers serve a dual purpose. In addition to facilitating airflow, they function as protective assemblies designed to resist ballistic and forced entry attacks, vandalism, and other security threats. However, the added security features, such as reinforced blades, thicker materials, tighter spacing, or integrated security screens, can restrict free air passage.

Because of these enhanced design characteristics and materials, maximum-security louvers often have lower free area and higher-pressure drop compared to standard louvers of the same size. To meet required airflow performance, overall louver size may need to be increased beyond that expected for non-security applications.

Proper coordination between airflow requirements, AMCA 500-L performance data, and security criteria is essential to ensure both mechanical system performance and safety objectives are achieved without compromising security requirements.

AIRFLOW PERFORMANCE

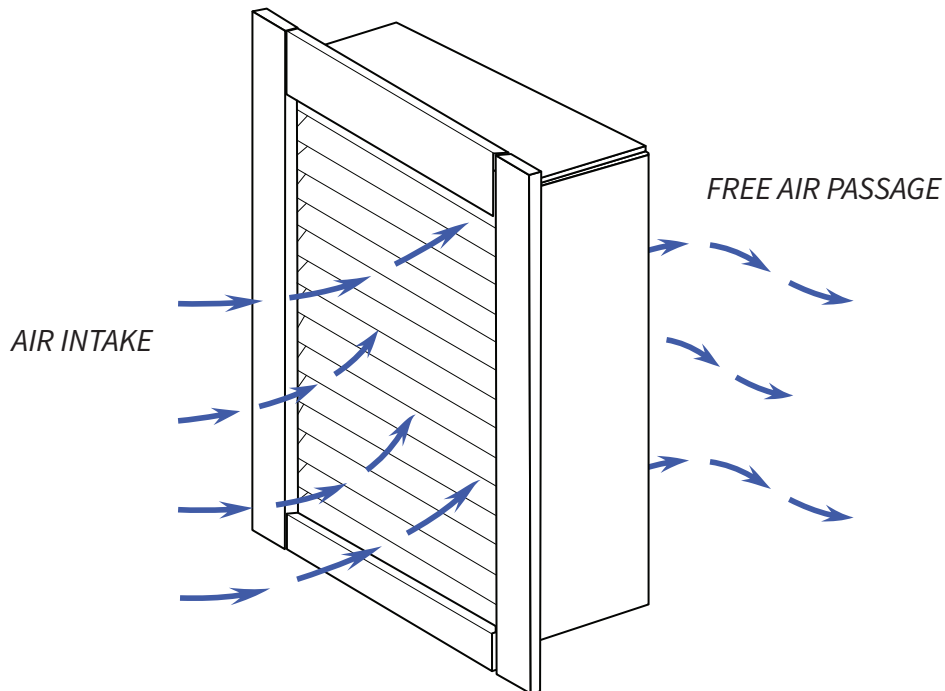

GEOGRAPHICAL REQUIREMENTS AND CONSIDERATIONS

Certain facility locations are subject to additional geographical and environmental considerations during design and planning. These requirements are often driven by the unique natural conditions and climate risks associated with a particular region.

In coastal environments, additional considerations come into play due to salt-laden air and high humidity, which significantly increase the risk of corrosion. In these cases, corrosion-resistant materials, protective coatings, hot-dip galvanized components, and enhanced maintenance are often required to ensure long-term durability and performance.

In areas prone to high winds, such as hurricane or tornado regions, structures must be designed to resist elevated wind loads, flying debris, and pressure differentials. These high wind velocities can affect everything from structural framing and roofing systems to exterior cladding and mounted equipment.

Taking these geographical factors into account early in the project lifecycle helps ensure structural integrity, regulatory compliance, operational reliability, and extended asset lifespan.

Other Relevant Standards to Consider:

- **UL 752 (12th Edition):** The most recent version of the UL 752 ballistic standard, maintaining similar ballistic protection levels and performance thresholds as the 11th Edition, while incorporating refined testing procedures, documentation, marking, and certification requirements to improve consistency and traceability
- **NIJ Standard 0108.01:** Evaluates ballistic-resistant protective materials, including architectural assemblies, armor plates, and shields
- **ASTM F3038-21:** Assesses forced-entry resistance of architectural assemblies by simulating a coordinated mob attack using consumer-grade hand tools. This commercially available test methodology is comparable to the forced-entry testing outlined in DOS SD-STD-01.01 (Rev G) Amended
- **AMCA 511:** Certified Ratings Program used in conjunction with AMCA 500 to verify and authorize AMCA performance ratings for air control and mechanical products
- **AMCA 540:** Requires louvers within 30 feet of grade in wind-borne debris regions to pass impact testing using a 2" × 4" timber projectile launched at specified velocities
- **AMCA 550:** Evaluates louvers for high-velocity wind-driven rain resistance at multiple wind speeds, limiting water penetration to less than 1%
- **ASHRAE Fundamentals:** Provides engineering methodologies for modeling ventilation, pressure drop, and overall HVAC/R system effects
- **IBC Chapter 16 / ASCE 7:** Defines minimum structural wind load requirements for buildings and components, including component and cladding pressures based on wind speed, exposure, and risk category
- **2021 International Mechanical Code (IMC) Section 401.5 – Intake Opening Protection:** Requires corrosion-resistant grilles or screens for outdoor air intakes in residential and commercial occupancies and mandates AMCA 550 compliance for louvers protecting air openings in hurricane-prone regions

Design Guidance:

Specify both ballistic resistance standards and ventilation performance criteria to ensure security requirements are met without compromising mechanical system performance or overall facility functionality.



BALLISTIC CONTINUITY ACROSS THE BUILDING ENVELOPE

A building envelope is only as strong as its weakest assembly. To prevent adversaries from exploiting discontinuities, ensure louvers match or exceed the ballistic rating of adjacent walls, doors, and glazing.

Key considerations include:

- Matching UL 752 or equivalent ratings across assemblies
- Ensuring no direct line-of-sight through airflow paths
- Preventing secondary fragmentation into protected spaces

True ballistic protection requires a holistic approach, not isolated components.

DESIGN FLEXIBILITY WITHOUT SACRIFICING PROTECTION

Despite their robust construction, ballistic-resistant louvers can be seamlessly incorporated into architectural designs. With a variety of finishes or by installing architectural / commercial louvers as a visual screen in front, they can blend into the façade while delivering concealed ballistic protection.

Functional flexibility is equally important. Depending on airflow and system requirements, louvers may need to be installed in non-standard orientations. Deviations from the tested configuration, such as installing the unit horizontally when it was tested in a vertical position, must be reviewed by the manufacturer or certification agency to ensure ballistic performance and airflow requirements are not compromised.

SPECIFICATION AND INSTALLATION CONSIDERATIONS

A ballistic-resistant louver must be securely anchored to a structure that is capable of withstanding the same ballistic resistance as the louver itself. If the adjacent wall or mounting substrate does not provide equivalent strength and support, the overall performance of the assembly may be compromised. In such cases, projectiles could circumvent the louver by causing failure in the surrounding structure rather than penetrating the louver directly.

Additionally, the supporting wall must have sufficient structural capacity to properly anchor and embed the louver assembly. If the wall is inadequately reinforced or constructed from weaker materials, it may not be able to support the weight of the louver or resist the imposed loads. Proper design and construction can reduce the risk of improper installation, anchorage failure, or structural damage. These issues can compromise both ballistic protection and the system's long-term performance.

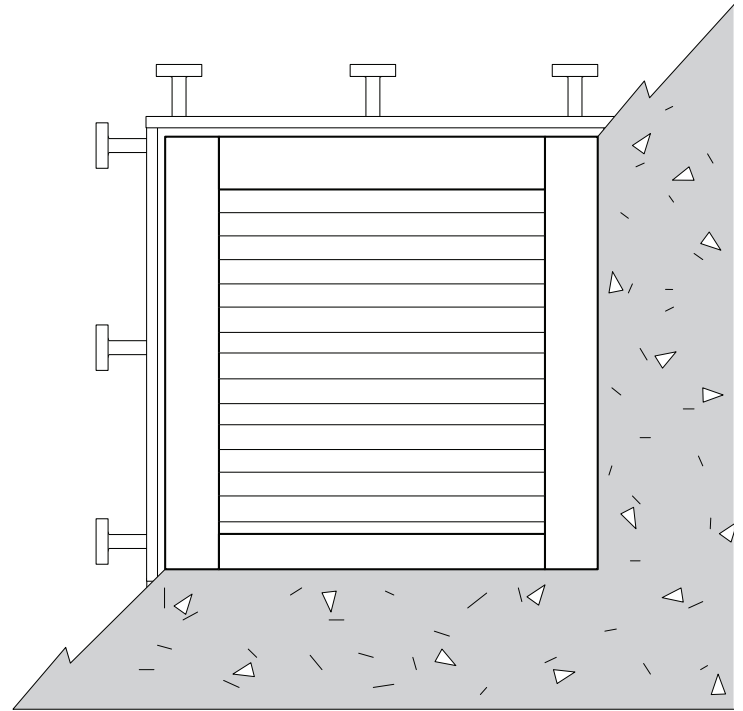

**EMBEDDED LOUVER
SUBFRAME**

CONCLUSION

Louvers are essential for ventilating data centers, generators, and mechanical systems. As ballistic threats continue to evolve, the building envelope must be evaluated as a complete protective system rather than a collection of independent components. Louvers, often overlooked as purely mechanical elements, represent critical openings that can either compromise or preserve the integrity of a hardened mission-critical facility. When properly engineered, tested, and installed, ballistic-resistant louvers maintain essential airflow while delivering protection against firearm and forced-entry threats.

Achieving this balance requires careful coordination of ballistic standards (UL, DOS, NIJ), mechanical performance criteria (AMCA 500-L, AMCA 550, AMCA 511, ASHRAE), and structural integration. By specifying louvers that match the protection level of adjacent assemblies and validating both security and airflow performance, design teams can ensure true ballistic continuity without sacrificing operational reliability. In high-security environments, protection and performance are not competing priorities. They must function together as a unified system.



31 INDUSTRIAL CIRCLE
LANCASTER PA 17601
PHONE: +01 717-308-9227
FAX: 717-556-8158
SALES@HARDENSECURE.COM
WWW.HARDENSECURE.COM